



Experience better living.

Latitude Commercial heat pump 20 & 40



Powerful, quietly efficient
heat pump for
commercial projects



1 Type and order code		LA2030CP	
2 Design			
2.1 Heat source			Air
2.2 Seasonal room heating energy efficiency η_s for average climate 35 °C / 55 °C		%	205 / 155
2.3 Seasonal coefficient of performance SCOP average climate 35 °C / 55 °C			5.20 / 3.96
2.4 Seasonal coefficient of performance SEER Fan convector/ cooled ceiling			3.94 / 4.77
2.5 Control			WPM
2.6 Thermal energy metering			Integrated
2.7 Installation location			Outdoors
2.8 Performance levels			Inverter
3 Operating limits			
3.1 Heating water flow		°C	Up to 70
3.2 Cooling water flow		°C	7 to 20
3.3 Air (heating)		°C	-22 to 40
3.4 Air (cooling)		°C	10 to 45
4 Flow			
4.1 Heating water flow/ internal pressure differential Nominal flow according to EN 14511	A7 / W35... 30	m ³ /h / Pa	2.0 / 20000
4.2 Minimum heating water flow rate		m ³ /h	2.0
4.3 Maximum heating / cooling water flow rate		m ³ /h	3.0
4.4 Minimum cooling water flow rate/ internal pressure differential		m ³ /h / Pa	2.0 / 20000
4.5 Air flow	Normal operation	m ³ /h	4600-9500
5 Sound			
5.1 Sound power level in accordance with EN 12102 (A7 /W55)	ErP in accordance with EN 12102	dB(A)	52
5.5 Sound pressure level (A7 / W55) free-standing installation at 10 m distance ³	ErP in accordance with EN 12102	dB(A)	24 (7.4 kW)
6 Dimensions, weight and filling quantities			
6.1 Device dimensions without connections	H x W x L	mm	1517 x 1800 x 885
6.2 Device connections for heating		Inch	R 1 1/4" thread-sealing external thread
6.3 Weight of device including packaging		kg	400
6.4 Refrigerant/ total filling weight		Type/ kg	R290 / 2.5
6.5 GWP value/ CO ₂ equivalent		- / t	3 / 0.01
6.6 Refrigeration circuit hermetically sealed			Yes
6.7 Lubricant/ total filling quantity		Type / l	PZ46M / 1.15
7 Electrical connection			
7.1 Supply voltage / fusing / RCD type			3~/PE 400 V (50 Hz) / C25 / B
7.2 Short-circuit ratio Rsce		-	≥ 350
7.3 Short-circuit capacity Ssc		VA	4782
7.4 Control voltage/fusing via WPM			1~/N/PE 230 V (50 Hz) / 6.3 AT
7.5 Degree of protection according to EN 60529			IP 24
7.6 Starting current			< I _b
7.7 Phase monitoring			Yes
7.8 Max. consumption / cos ϕ		kW / -	12.5 / 0.99
7.9 Max. operating current		A	22.3
7.10 Crank case heater power consumption (regulated)		W	70
7.11 Power consumption, fan		W	< 700
7.12 Power consumption for A2 / W35 min./max.		kW	1.45 / 4.66
8 Additional model features			
8.1 Type of defrosting			Reverse circulation
8.2 Condensate tray frost protection / water in device is protected from freezing ⁴			Yes
8.3 Max. operating overpressure (heat sink)		bar	4.5

1. The maximum sound power level can increase depending on the flow temperature, the required heat output and the current outside temperature.

2. The sound power level can be used to calculate the guideline immission value in accordance with German Noise Prevention Code for the Average climatic region in a mid-temperature application.

3. Calculated for open air installation. The installation-specific sound pressure level can be calculated under www.waermepumpe.de/werkzeuge/schallrechner for different installation variants.

4. The heat circulating pump and the heat pump controller must always be ready for operation.

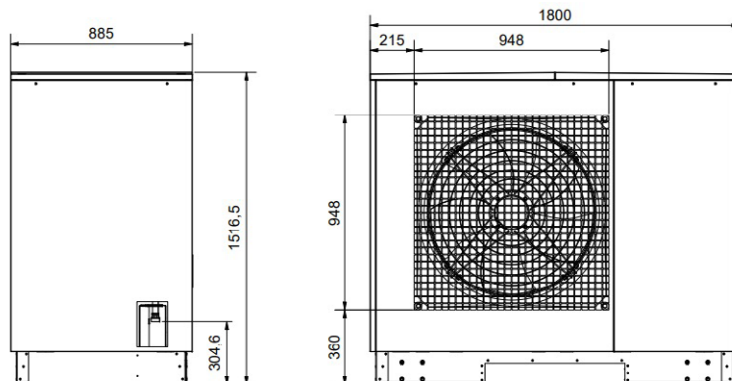

High-efficiency heating and cooling - Latitude Commercial 20 kW

Heating			
Measuring point		Output (kW)	COP
A-7 / W35	min	8.8	3.6
	max	19.6	2.8
A2 / W35*	min	6.8	4.7
	max	17.4	3.7

Cooling			
Measuring point		Output (kW)	COP
A35 / W7	min	8.4	3.4
	max	13.0	2.9
A35 / W18	min	11.3	4.5
	max	17.6	3.7

* Including defrosting according to EN 14511



1 Type and order code		LA4060CP	
2 Design			
2.1 Heat source			Air
2.2 Seasonal room heating energy efficiency η_s for average climate 35 °C / 55 °C		%	186 / 149
2.3 Seasonal coefficient of performance SCOP average climate 35 °C / 55 °C			4.72 / 3.80
2.4 Seasonal coefficient of performance SEER Fan convector/ cooled ceiling			3.58 / 4.08
2.5 Control			WPM
2.6 Thermal energy metering			Integrated
2.7 Installation location			Outdoors
2.8 Performance levels			Inverter
3 Operating limits			
3.1 Heating water flow		°C	Up to 70
3.2 Cooling water flow		°C	7 to 20
3.3 Air (heating)		°C	-22 to 40
3.4 Air (cooling)		°C	10 to 45
4 Flow			
4.1 Heating water flow/ internal pressure differential Nominal flow according to EN 14511	A7 / W35... 30	m ³ /h / Pa	4.0 / 40000
4.2 Minimum heating water flow rate		m ³ /h	4.0
4.3 Maximum heating / cooling water flow rate		m ³ /h	5.0
4.4 Minimum cooling water flow rate/ internal pressure differential		m ³ /h / Pa	4.0 / 40000
4.5 Air flow	Normal operation	m ³ /h	6500-14600
5 Sound			
5.1 Sound power level in accordance with EN 12102 (A7 / W55)	ErP in accordance with EN 12102	dB(A)	55
5.2 Sound pressure level (A7 / W55) free-standing installation at 10 m distance ³	ErP in accordance with EN 12102	dB(A)	27
6 Dimensions, weight and filling quantities			
6.1 Device dimensions without connections	H x W x L	mm	1764 × 1970 × 1000
6.2 Device connections for heating		Inch	R 2 thread-sealing external thread
6.3 Weight of device including packaging		kg	566
6.4 Refrigerant/ total filling weight		Type/ kg	R290 / 4.0
6.5 GWP value/ CO ₂ equivalent		- / t	3 / 0.012
6.6 Refrigeration circuit hermetically sealed			Yes
6.7 Lubricant/ total filling quantity		Type / l	160SZ / 3.6
7 Electrical connection			
7.1 Supply voltage / fusing / RCD type			3~/PE 400 V (50 Hz) / C50 / B
7.2 Short-circuit ratio Rsce		-	≥ 250
7.3 Short-circuit capacity Ssc		VA	8625
7.4 Control voltage/fusing via WPM			1~/N/PE 230 V (50 Hz) / 6.3 AT
7.5 Degree of protection according to EN 60529			IP 24
7.6 Starting current			< I _b
7.7 Phase monitoring			Yes
7.8 Max. consumption / cos ϕ		kW / -	26 / 0.99
7.9 Max. operating current		A	40.6
7.10 Crank case heater power consumption (regulated)		W	65
7.11 Power consumption, fan		W	< 1950
7.12 Power consumption for A2 / W35 min./max.		kW	4.6 / 10.5
8 Additional model features			
8.1 Type of defrosting			Reverse circulation
8.2 Condensate tray frost protection / water in device is protected from freezing ⁴			Yes
8.3 Max. operating overpressure (heat sink)		bar	4.5

1. The maximum sound power level can increase depending on the flow temperature, the required heat output and the current outside temperature.

2. The sound power level can be used to calculate the guideline immission value in accordance with German Noise Prevention Code for the Average climatic region in a mid-temperature application.

3. Calculated for open air installation. The installation-specific sound pressure level can be calculated under www.waermepumpe.de/werkzeuge/schallrechner for different installation variants.

4. The heat circulating pump and the heat pump controller must always be ready for operation.

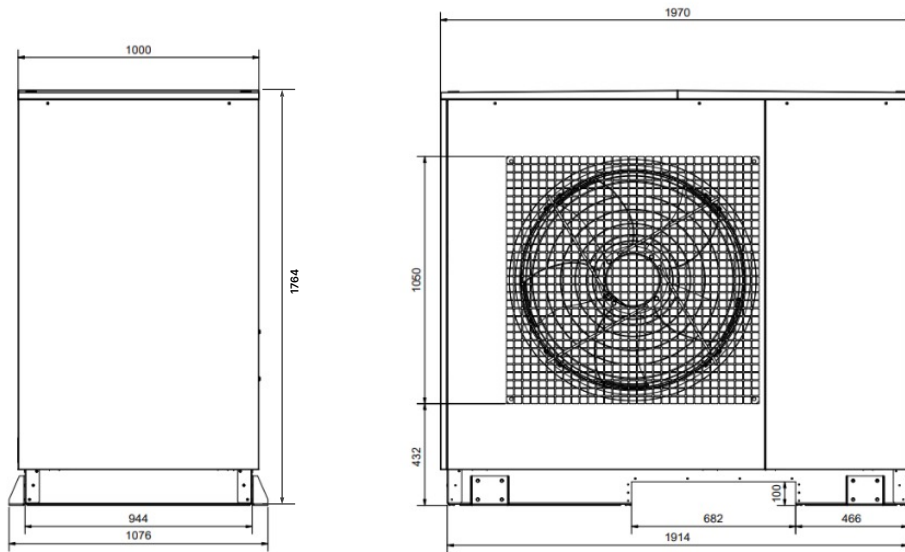

High-efficiency heating and cooling - Latitude Commercial - 40 kW

Heating			
Measuring point		Output (kW)	COP
A-7 / W35	min	23.4	3.3
	max	42.5	2.7
A2 / W35*	min	19.0	4.1
	max	35.7	3.4

Cooling			
Measuring point		Output (kW)	COP
A35 / W7	min	12.9	3.0
	max	24.0	2.8
A35 / W18	min	15.6	3.5
	max	30.1	3.4

* Including defrosting according to EN 14511





Dimplex[®]

Experience better living.

🌐 www.dimplex.co.uk

☎ 0344 879 3586

✉ pre-sales@glendimplex.com

📍 Dimplex, Millbrook House, Grange Drive, Hedge End
Southampton, Hampshire, United Kingdom SO30 2DF

Dimplex reserves the right to amend or revise product specification without notice. The information in this publication is correct at the time of publication. The information herein should not be read in isolation as it is meant only as guidance for the user, who should always ensure that they are fully conversant with the products and systems being used and their subsequent installation prior to the commencement of work.

For an up-to-date library of product information, users should visit the website at dimplex.co.uk

Glen Dimplex UK Limited Registered in England. Company Number 1313016.

Registered Offices: Glen Dimplex Heating & Ventilation, Millbrook House, Grange Drive, Hedge End, Southampton, Hampshire, United Kingdom, SO30 2DF